

FRIGID-X™ VORTEX TUBES

Produce cold air as low as minus 50°F (minus 46°C) from compressed air with no moving parts to spot cool or cool enclosures with no electricity

WHAT ARE THEY - REASONS TO USE

Vortex Tubes are devices that work on a standard compressed air supply. Air enters the vortex tube and is literally split into two parts - cold air at one end, and hot air at the other - all without any moving parts.

Vortex Tubes have an adjustable valve at the "hot" end which controls the volume of the air flow, and the temperature exiting at the cold end. By adjusting the valve, you control the "cold fraction" which is the percentage of total input compressed air that exits the cold end of the Vortex Tube. Our Vortex Tubes may also be supplied with a fixed preset "cold fraction" instead of an adjustable valve.

Inside is the interchangeable brass "generator" which can alter the air used in the Vortex Tube, and control the temperature ranges you wish to have at the cold and hot ends. There are several ranges of generators for compressed air capacity. There are also two basic types of generators - one to produce the extreme cold temperatures (maximum cold temperature out called the C generator) and one type to produce the maximum amount of cooling (maximum refrigeration called the H generator).



WHY THE FRIGID-X™ VORTEX TUBE OVER OTHERS :

The Frigid-X™ Vortex Tube is constructed of stainless steel and uses a generator and valve made of brass and sealed with viton o-rings to allow their use in the widest range of environments. This also allows for greater life and better consistency between Vortex Tubes made. In addition, it is usable in high temperature environments AS IT COMES with NO extra charge unlike many of our competitors.

Most competitors use plastic generators and standard Buna N O-Rings and charge extra for brass and high temperature-rings. The unique design and quality of materials used in Frigid-X™ products will deliver years of maintenance-free operation.

FRIGID-X™ VORTEX TUBE ADVANTAGES:

- ▶ No moving parts.
- ▶ Driven by air not electricity.
- ▶ Small and lightweight - portable.
- ▶ Low in cost compared to most others
- ▶ Superior design and performance
- ▶ Maintenance free operation
- ▶ Made of durable stainless steel and metal parts - no cheap plastic parts
- ▶ Adjustable temperature range
- ▶ Generators are interchangeable

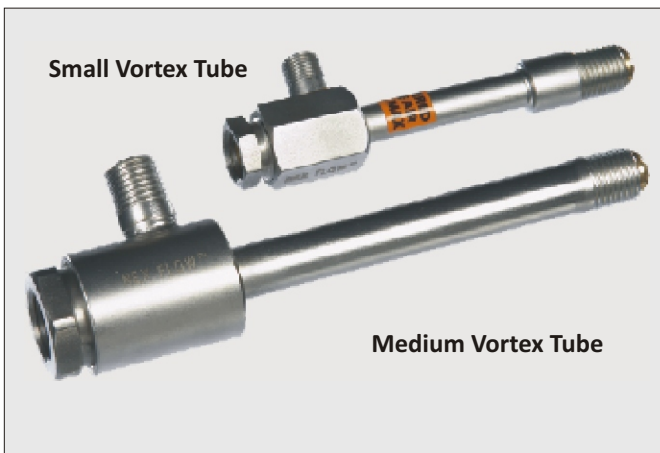

FRIGID-X™ VORTEX TUBE - HOW IT WORKS

Compressed air enters at point (A). Inside the tube the compressed air is made to spin using a "generator". It travels in one direction along the small (hot end) tube and then back inside itself in the reverse direction creating one stream of air (B) and the second stream of air (C) in the opposite direction. The outside stream of air gets hot and exhausts at point (D). The center column of air gets cold and exists at point (E). Temperatures and capacities can vary by adjusting the hot end plug at (D) and by using different "generators"

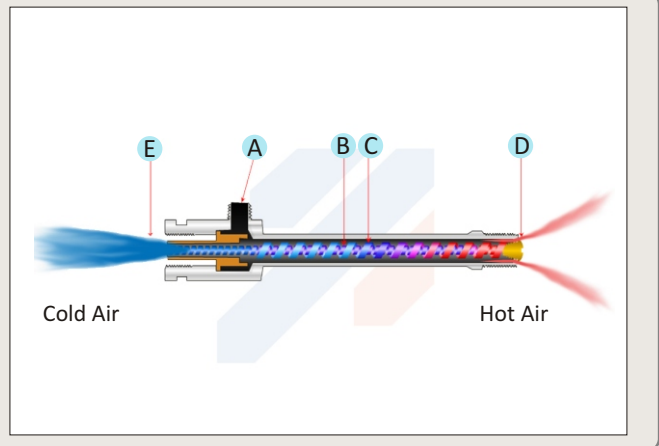

Due to space limitation & the need to eliminate water cooling the camera, a Model 50025H Vortex Tube was used to cool a camera housing.

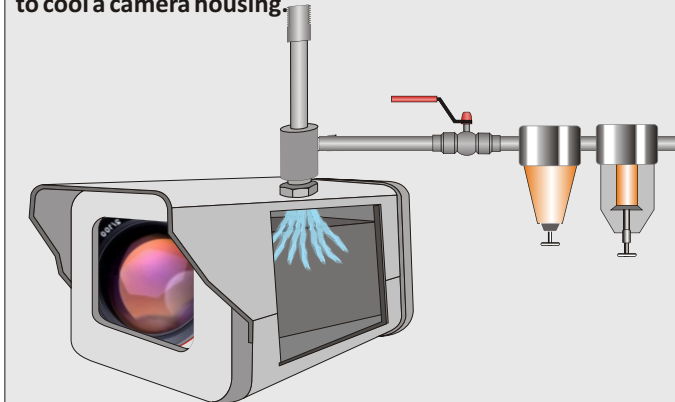

Two Vortex Tubes model 50030H with a Model 55002 Muffler cools and Ultrasonic Welding Horn.

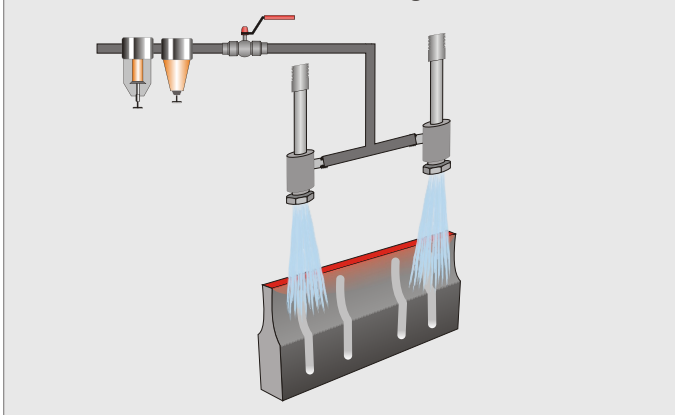

FRIGID-X™ VORTEX TUBE EXPERIMENTAL KITS

Two Experimental Kits are available (small Vortex Tube kit and medium size Vortex Tube kit) which contains the appropriate Vortex Tube, all generators for that size, cold end muffler and filter with auto drain to do testing if you are not certain of what exact size you require.

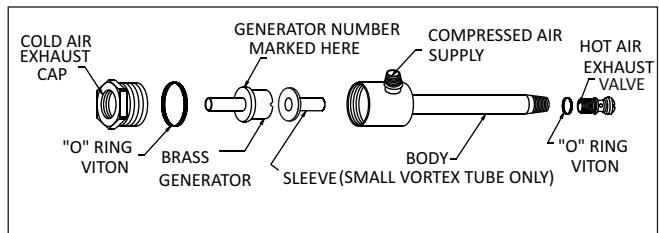

CONTROLLING THE FLOW RATE AND TEMPERATURE IN THE FRIGID-X™ VORTEX TUBE

The flow rate and temperature in a Vortex Tube are interdependent. When you open the adjusting valve at the hot end, the cold air flow decreases and the temperature drops. As you close the valve the cold air end flow increases and temperature rises. The percentage of the total input air that exits the cold end is termed the "cold fraction". Depending on inlet air temperature a cold fraction of between 60% and 80% produces the optimum combination of flow and temperature drop for maximum cooling effect, when using an H generator. Lower cold fractions produce colder air but do not cool as well because of reduced flow. Most industrial applications require the 60% to 80% setting and the H generator for optimal cooling.

In some instances such as cooling laboratory samples, testing circuit boards and other "cryogenic" applications, a 'C' generator is used which limits the cold end flow rate to lower levels and produces very cold temperatures.

To set the Vortex Tube to the desired temperature simply insert a thermometer at the cold end and adjust the hot end valve. The optimum cooling effect is achieved when the difference from the inlet air temperature and the cold air drops is 50° F (28° C) if the inlet air is relatively cool to 80° F (45° C) below compressed air temperature if the inlet air is relatively hot.

FRIGID-X™ VORTEX TUBES & SPOT COOLING

There are two basic physical sizes of Vortex Tubes used extensively in industry - the small and medium size. A larger version is available on special order. Frigid-X™ Vortex Tubes can be selected by required performance in cooling for the 'H' generator versions and where very cold temperature is required, the 'C' generators are used. However, even with 'C' generators, as expected, the higher the are flow rating the greater any cooling effect.

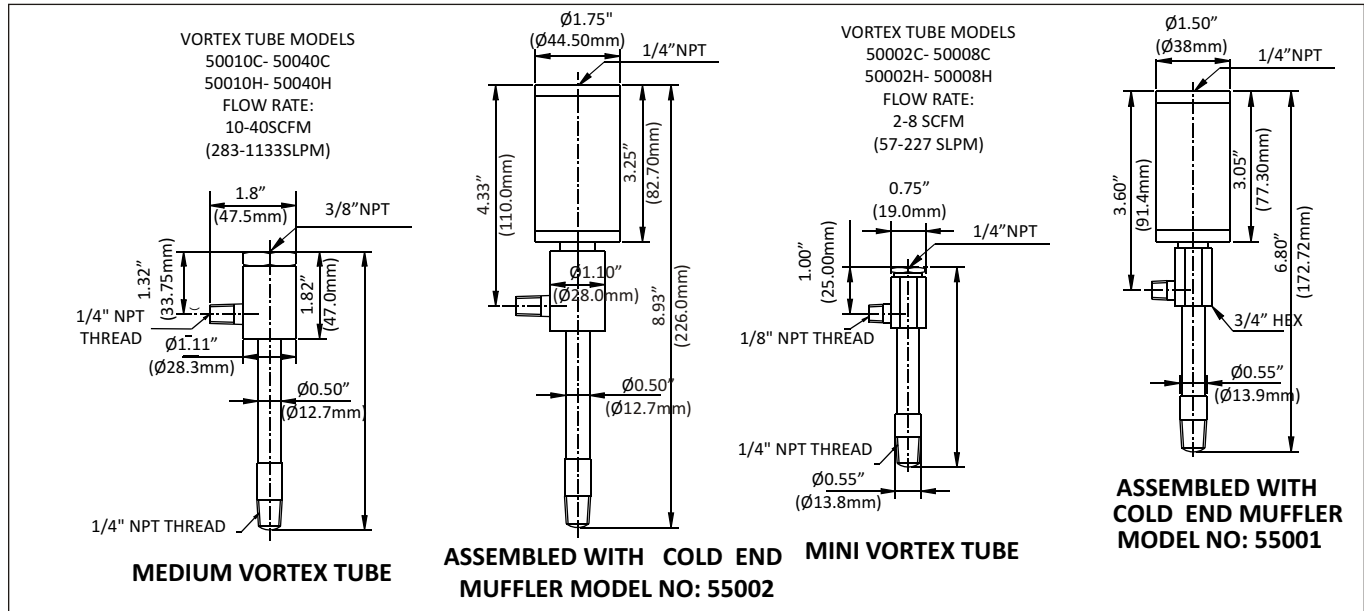

H series Vortex Tubes (For Maximum Cooling)					
MODEL NO.	SCFM	SLPM	BTU/Hr.	WATTS	SIZE
50002H	2	57	145	42	small
50004H	4	113	290	85	small
50008H	8	227	580	170	small
50010H	10	283	730	214	medium
50015H	15	425	1100	322	medium
50025H	25	708	1800	527	medium
50030H	30	850	2100	615	medium
50040H	40	1133	2900	849	medium

C series Vortex Tubes (For Maximum Cold Temperature)					
MODEL NO.	SCFM	SLPM	BTU/Hr.	WATTS	SIZE
50002C	2	57	N/A	N/A	small
50004C	4	113	N/A	N/A	small
50008C	8	227	N/A	N/A	small
50010C	10	283	N/A	N/A	medium
50015C	15	425	N/A	N/A	medium
50025C	25	708	N/A	N/A	medium
50030C	30	850	N/A	N/A	medium
50040C	40	1133	N/A	N/A	medium

NOTE:

1. SCFM and SLPM at 100 PSIG or 6.9 bar Inlet Pressure
2. BTU/hr and Watts is Cooling Capacity at 100 PSIG or 6.9 bar inlet pressure and with optimal cold fraction setting

NOTE:

1. SCFM and SLPM at 100 PSIG or 6.9 bar Inlet Pressure
2. BTU/hr and Watts not applicable as normally not used for air conditioning applications

Approximate temperature drops (and rises) from inlet air temperature produced by a Vortex Tube set at various cold fractions. Assume constant inlet pressure and temperature. Tests were conducted with a 15H generator in a medium size Vortex Tube (Model 50015H). Will vary with other sizes and capacities.

PRESSURE SUPPLY	COLD FRACTION %						
	20	30	40	50	60	70	80
20 (1.4)	62 (34)	60 (33)	56 (31)	51 (28)	44 (24)	36 (20)	28 (16)
	15 (8)	25 (14)	36 (20)	50 (28)	64 (26)	83 (46)	107 (59)
40 (2.8)	88 (48)	85 (46)	80 (42)	73 (39)	63 (34)	52 (28)	38 (20)
	21 (11)	35 (18)	52 (28)	71 (38)	92 (50)	117 (62)	147 (80)
60 (4.1)	104 (57)	100 (55)	93 (51)	84 (46)	73 (40)	60 (33)	46 (25)
	24 (14)	40 (22)	59 (33)	80 (44)	104 (57)	132 (73)	166 (92)
80 (5.5)	115 (63)	110 (62)	102 (56)	92 (51)	80 (45)	66 (36)	50 (28)
	25 (14)	43 (24)	63 (35)	86 (47)	113 (63)	143 (80)	180 (100)
100 (6.9)	123 (68)	118 (65)	110 (61)	100 (55)	86 (48)	71 (39)	54 (30)
	26 (14)	45 (25)	67 (37)	90 (50)	119 (66)	151 (84)	191 (106)
120 (8.4)	129 (72)	124 (69)	116 (64)	104 (58)	91 (50)	74 (41)	55 (31)
	26 (14)	46 (26)	69 (38)	94 (52)	123 (68)	156 (86)	195 (108)

Temperature drop of cold air, °F (°C) in blue

Temperature rise of hot air, °F (°C) in red

USING THE VORTEX TUBE :

Back pressures over 2 psig (0.1 bar) can reduce the performance of a Vortex Tube. Similarly it is important to use a minimum of 25 micron or less filtration to keep the air clean and dry. Vortex tubes alone without ducting can be noisy so mufflers are available for both the cold end and hot end. All of our Vortex Tubes are built to be used in even high temperature environments at no extra cost.

VORTEX TUBE THEORIES :

There are many theories of the Vortex Tube also known as the Ranque Vortex Tube, the Hilsch Tube, Maxwell’s Demon Tube, and the Ranque - Hilsch Tube. Invented in 1933 by French physicist Georges J. Ranque and improved upon by German physicist Rudolf Hilsch in a notable paper published in 1947, there is a great deal of information available on the internet.

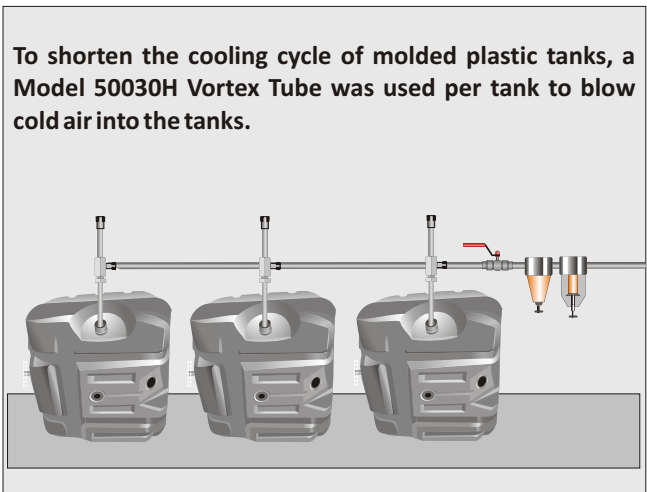

To shorten the cooling cycle of molded plastic tanks, a Model 50030H Vortex Tube was used per tank to blow cold air into the tanks.

FRIGID-X™ VORTEX TUBES & SPOT COOLING

FRIGID-X™ VORTEX TUBES

Part No.	Description
50002H	Small Vortex Tube with 2H Generator for Maximum cooling Effect
50004H	Small Vortex Tube with 4H Generator for Maximum cooling Effect
50008H	Small Vortex Tube with 8H Generator for Maximum cooling Effect
50010H	Medium Vortex Tube with 10H Generator for Maximum cooling Effect
50015H	Medium Vortex Tube with 15H Generator for Maximum cooling Effect
50025H	Medium Vortex Tube with 25H Generator for Maximum cooling Effect
50025H	Medium Vortex Tube with 30H Generator for Maximum cooling Effect
50040H	Medium Vortex Tube with 40H Generator for Maximum cooling Effect
50002C	Small Vortex Tube with 2C Generator for Maximum Cold Temperature
50004C	Small Vortex Tube with 4C Generator for Maximum Cold Temperature
50008C	Small Vortex Tube with 8C Generator for Maximum Cold Temperature
50010C	Medium Vortex Tube with 10C Generator for Maximum Cold Temperature
50015C	Medium Vortex Tube with 15C Generator for Maximum Cold Temperature
50025C	Medium Vortex Tube with 25C Generator for Maximum Cold Temperature
50030C	Medium Vortex Tube with 30C Generator for Maximum Cold Temperature
50040C	Medium Vortex Tube with 40C Generator for Maximum Cold Temperature
55001	Cold End Muffler for small Vortex Tube
55002	Cold End Muffler for Medium Vortex Tube
55003	Hot End Muffler for Small or Medium Vortex Tube
51008K	Small Vortex Tube test Kit. Consists of Small Vortex Tube, Cold Muffler, Filter with auto drain, and Generators - 2C, 2H, 4C, 4H, 8C, 8H
51040K	Medium Vortex Tube test Kit. Consists of Medium Vortex Tube, Cold Muffler, Filter with auto drain, and Generators - 10C, 10H, 15C, 15H, 25C, 25H, 30C, 30H, 40C, 40H
59008K	Small Vortex Tube Generator Kit Generators - 2C, 2H, 4C, 4H, 8C, 8H
59040K	Medium Vortex Tube Generator Kit Generators - 10C, 10H, 15C, 15H, 25C, 25H, 30C,30H, 40C, 40H

NOTE: The last two numbers in the part number indicate the SCFM consumption at 100 PSIG (6.9 Bar) - Example 50025C indicates 25 SCFM air consumption at 100 PSIG (6.9 Bar).

The PLCFC described in Section A is an effective means to control energy used by turning on and off the Vortex Tubes as required.



FRIGID-X™ VORTEX TUBES

Part No.	Description
59002C	2 SCFM Small Vortex Tube Brass Generator Only - Cold Temp.
59004C	4 SCFM Small Vortex Tube Brass Generator Only - Cold Temp.
59008C	8 SCFM Small Vortex Tube Brass Generator Only - Cold Temp.
59002H	2 SCFM Small Vortex Tube Brass Generator Only - Max. BTU/hr
59004H	4 SCFM Small Vortex Tube Brass Generator Only - Max. BTU/hr
59008H	8 SCFM Small Vortex Tube Brass Generator Only - Max. BTU/hr
59010C	10 SCFM Medium Vortex Tube Brass Generator Only - Cold Temp.
59015C	15 SCFM Medium Vortex Tube Brass Generator Only - Cold Temp.
59025C	25 SCFM Medium Vortex Tube Brass Generator Only - Cold Temp.
59030C	30 SCFM Medium Vortex Tube Brass Generator Only - Cold Temp.
59040C	40 SCFM Medium Vortex Tube Brass Generator Only - Cold Temp.
59010H	10 SCFM Medium Vortex Tube Brass Generator Only - Max. BTU/Hr.
59015H	15 SCFM Medium Vortex Tube Brass Generator Only - Max. BTU/Hr.
59025H	25 SCFM Medium Vortex Tube Brass Generator Only - Max. BTU/Hr.
59030H	30 SCFM Medium Vortex Tube Brass Generator Only - Max. BTU/Hr.
59040H	40 SCFM Medium Vortex Tube Brass Generator Only - Max. BTU/Hr.

Accessories

90001	3/8" NPT Filter with automatic drain - 65 SCFM (1841 SLPM) capacity
90005	3/8" NPT Oil Removal Filter with automatic drain - 15 - 37 SCFM (425 - 1048 SLPM) capacity
90006	3/4" NPT Oil Removal Filter with automatic drain - 50 - 150 SCFM (1415 - 4248 SLPM) capacity

FRIGID-X™ VORTEX TUBES & SPOT COOLING

FRIGID-X™ ADJUSTABLE SPOT COOLER

Produce cold air as low as minus 30° F (minus 34° C) from compressed air to spot cool with easy adjustability

WHAT ARE THEY - REASONS TO USE

The Frigid-X™ Adjustable Spot Cooler is a low cost and maintenance free system which utilizes a vortex tube to produce cold air at one end.

The Frigid-X™ Adjustable Spot Cooler temperature can be adjusted using a knob at the hot end to set the temperature precisely to your requirements. Temperatures range from approximately minus 30°F to room temperature and can be easily set with a thermometer.

The Frigid-X™ Adjustable Spot Cooler System comes with three brass generators for flow rate adjustment - 15 SCFM (425 SLPM), 25 SCFM (708 SLPM) and 30 SCFM (850 SLPM) providing refrigeration up to 2100 BTU/hr (615 Watts).

Cold air is directed using the flexible tubing. A magnetic base is standard for portability and easy mounting of the adjustable spot cooler.

Units are available with either a single point hose kit for small surface area or a dual point hose kit when heat is generated over a larger surface area. Adjustable spot cooler produces a wide range of airflow and temperature by adjusting the knob at the hot end and changing the various generators supplied.

The generators control the air consumption and are easily interchangeable. Adjustable spot cooler has a 25 SCFM (708 SLPM) generator installed that will produce up to 1,800 Btu/hr. of cooling. If less is required, the 15 SCFM (425 SLPM) generator can deliver 1,100 BTU/Hr. If more cooling is needed Nex Flow™ can supply you with the 30 SCFM (850 SLPM) generator for up to 2,100 BTU/Hr. of cooling.

WHY THE FRIGID-X™ ADJUSTABLE SPOT COOLER OVER OTHERS:

All Metal Parts, Stainless Steel Body, Quiet - Tests Show Frigid-X™ Adjustable Spot Cooler is consistently more quiet than the competition.



FRIGID-X™ ADJUSTABLE SPOT COOLER ADVANTAGES:

- ▶ No moving parts.
- ▶ Quiet
- ▶ Driven by air not electricity.
- ▶ Small and lightweight - portable.
- ▶ Low in cost compared to most others
- ▶ Superior design and performance
- ▶ Maintenance free operation
- ▶ Made of durable stainless steel and metal parts, no cheap plastic parts
- ▶ Adjustable temperature range
- ▶ Generators are interchangeable
- ▶ System uses strong magnetic base

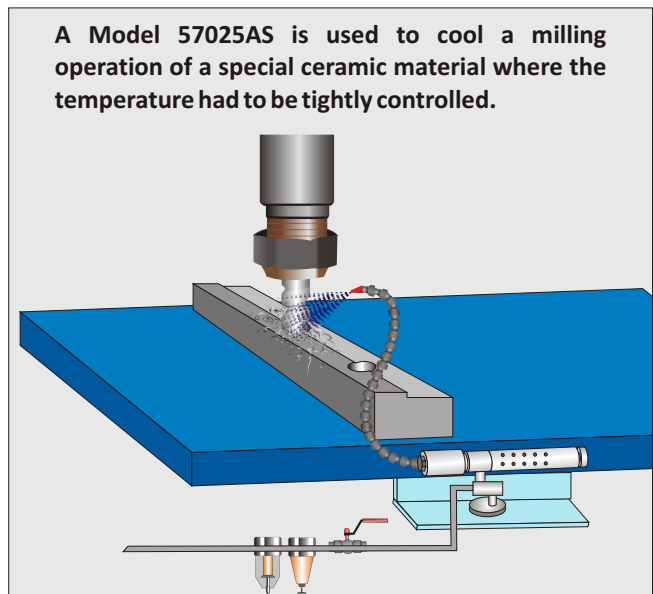

A Model 57025AS is used to cool a milling operation of a special ceramic material where the temperature had to be tightly controlled.



FRIGID-X™ ADJUSTABLE SPOT COOLER – HOW IT WORKS

Frigid-X™ - Adjustable Spot Cooler - Compressed air enters at point (A) into the vortex tube component of the spot cooler. The vortex tube splits the compressed air into a hot (B) and cold (C) stream of air. The hot air from the vortex tube is vented to the atmosphere at point (D) after being muffled to reduce noise. Cold air enters into the muffler (E) and then distributed through the hose distribution kit (F) and onto the item being cooled. A strong magnet (G) holds the spot cooler in place. The temperature of the cold air is controlled by an adjustable knob.

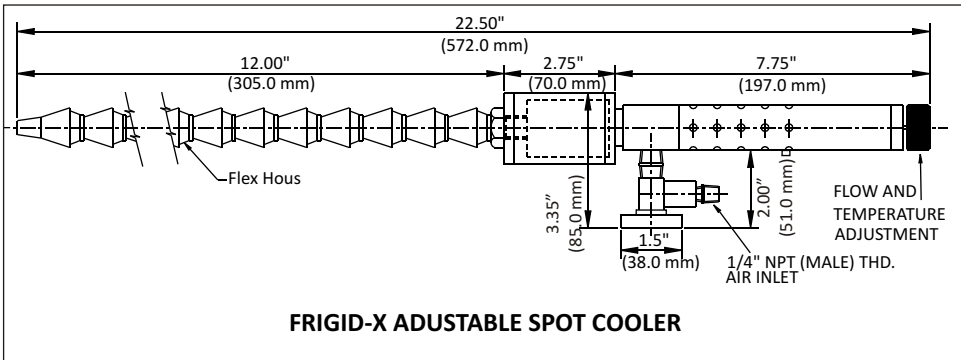
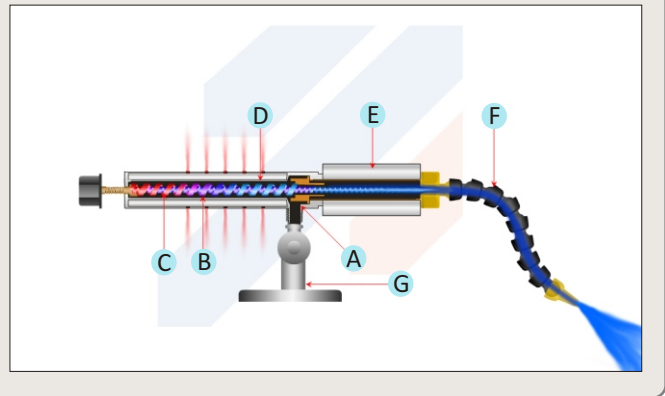

FRIGID-X ADJUSTABLE SPOT COOLER

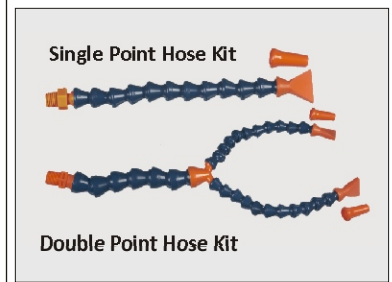

FRIGID-X™ ADJUSTABLE SPOT COOLER APPLICATIONS:

- ▶ Solder Cooling
- ▶ Adjusting thermostats
- ▶ Cool plastic machined parts
- ▶ Set hot melt adhesives
- ▶ Cool welding horns on ultrasonic
- ▶ Cool molded plastics
- ▶ Cool Electronic components
- ▶ Cool heat shrink tubing

INLET PRESSURE PSIG (Bar)	AIR CONSUMPTION SCFM (SLPM)	SOUND LEVEL dBA
100 (6.9)	15 (425)	70
100 (6.9)	25 (708)	71
100 (6.9)	30 (850)	72

A Model 57025AS is used to cool a special material on a lathe. A specific temperature was needed due the special material being machined.

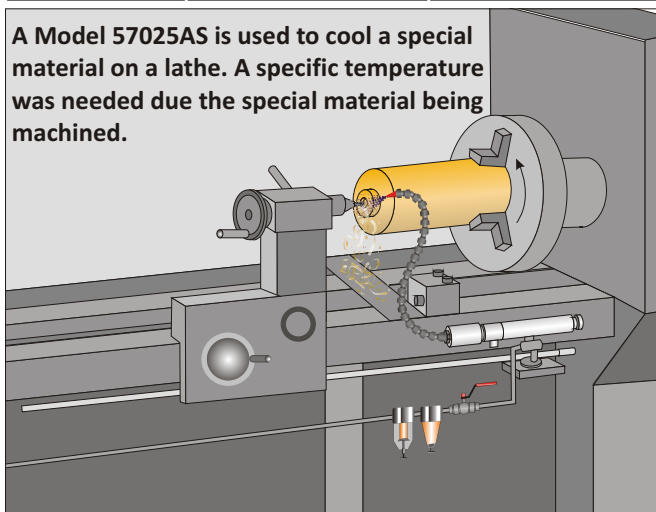

FRIGID-X™ ADJUSTABLE SPOT COOLER

PART NO.	DESCRIPTION
57025AS	Frigid-X™ Adjustable Spot Cooler System c/w cooler, magnetic base, single point hose kit, 25H generator (Installed), 15H generator (loose), 30H generator (loose)
57025AD	Frigid-X™ Adjustable Spot Cooler System c/w cooler, magnetic base, dual point hose kit, 25H generator (installed), 15H generator (loose), 30H generator (loose)
56025A	FRIGID-X™ Adjustable Spot Cooler only

OPTIONS

90001	Filter with automatic drain, 3/8" NPT, 65 SCFM (1841 SLPM)
90005	Oil Removal Filter, 3/8" NPT, 15-37 SCFM (425 to 1048 SLPM)

FRIGID-X™ VORTEX TUBES & SPOT COOLING

FRIGID-X™ MINI SPOT COOLER

Cool small parts and tooling with a compact spot cooler with no moving parts.

WHAT ARE THEY - REASONS TO USE

The Frigid-X™ Mini Spot Cooler is a low cost and maintenance free system which utilizes a vortex tube to produce cold air at one end. It is quiet and compact.

Designed for small parts, the Frigid-X™ Mini Spot Cooler produces a stream of 15 to 20 degree F (minus 9.5 to 7 degree C) of cold air to prevent heat buildup depending in inlet air temperature. It can improve tolerances in machining of small critical parts and increase production rates.

Cold air is directed using the flexible tubing. A magnetic base is standard for portability and easy mounting of the mini spot cooler

APPLICATIONS:

- ▶ Needle cooling on sewing machines
- ▶ Cooling small blades
- ▶ Grinding lenses and small parts
- ▶ Cooling small tools

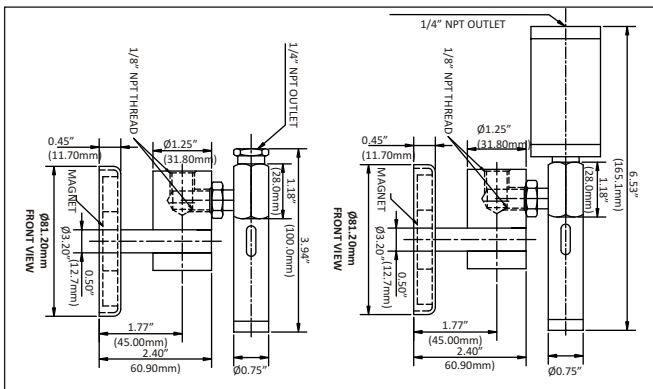

FRIGID-X™ MINI SPOT COOLER

PART NO.	DESCRIPTION
56008F	Mini Frigid-X™ Cooler only (no muffler)
56108F	Mini Frigid-X™ Cooler only (with muffler)
57008F	Frigid-X™ Mini Spot Cooler System c/w cooler, magnetic base, single point hose kit
56008F	Frigid-X™ Mini Spot Cooler only options
90003	Filter with Manual Drain ¼" NPT



The Mini Spot Cooler utilizes a vortex tube to create one hot stream and one cold stream (see page 9). The cold air produced at the cold end is directed to the surface to be cooled using a flexible hose.

The Mini Spot Cooler is used in the cooling of needles on a sewing machine used to produce heavy materials for carpeting.

